

MC 20

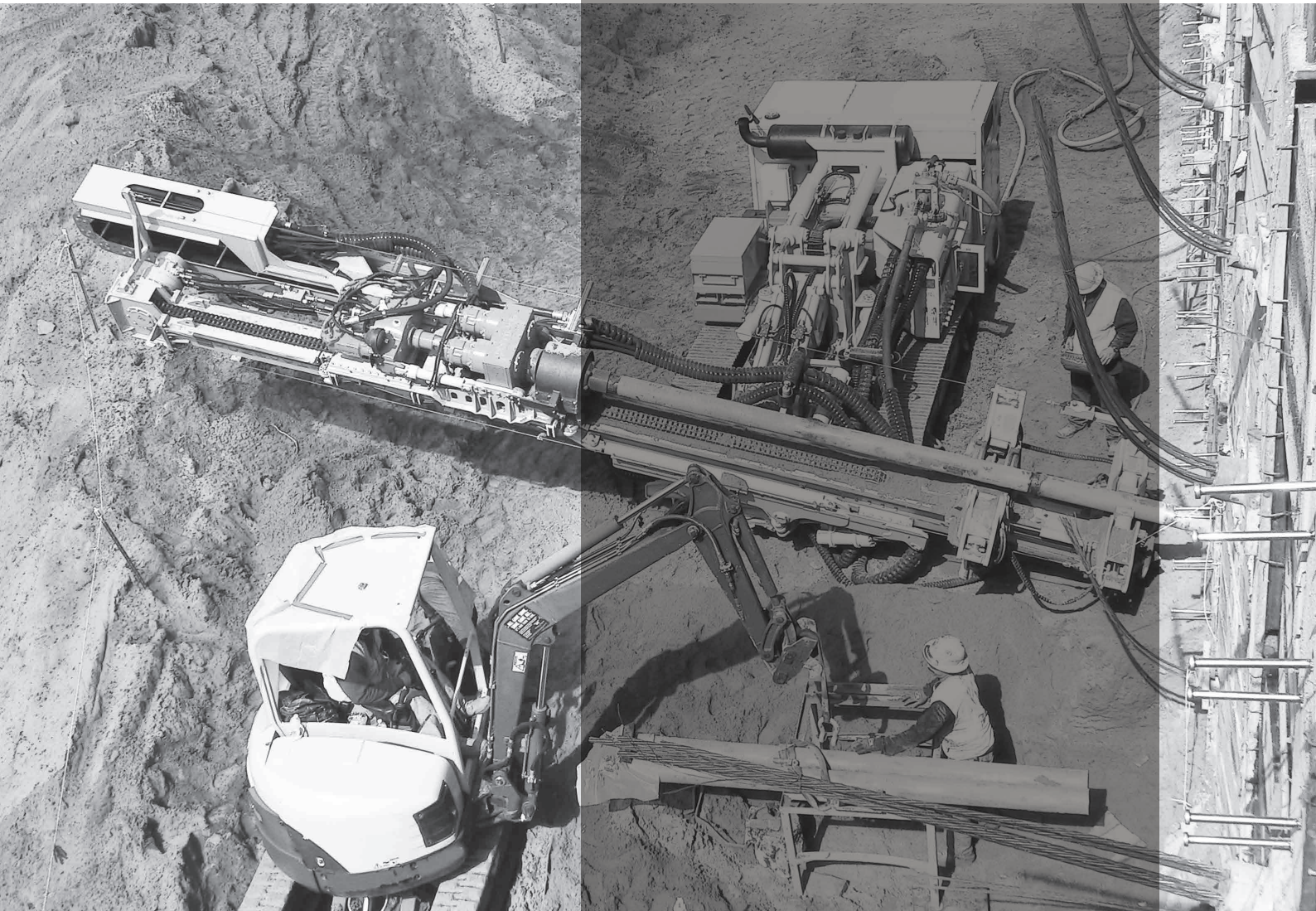

High Tech Line



COMACCHIO

DRILLING HI-TECH

Perforatrice idraulica
Hydraulic drill rig
Foreuse hydraulique
Hydraulisches Bohrgerät

MC 20

Varietà di movimenti

La **MC 20** è una perforatrice idraulica progettata per opere di ingegneria civile quali micropali, ancoraggi e consolidamenti in genere. Tratto distintivo della **MC 20** è la varietà di posizionamenti e inclinazioni raggiungibili grazie al sistema brevettato di articolazione del mast, abbinata a elevate prestazioni e affidabilità, che le permettono di affrontare anche le condizioni di lavoro più gravose. Dotata di circuiti idraulici modulari di concezione avanzata, la **MC 20** può montare una vasta scelta di teste di rotazione, martelli idraulici, sistemi doppia testa rotary-rotary e rotary-drifter ed è in grado di operare ogni tipo di perforazione a rotazione o roto-percussione. La **MC 20** può essere dotata di comandi idraulici proporzionali servo assistiti o dell'innovativo sistema di radiocomando **Comacchio** per il controllo di tutte le funzioni della macchina. Come tutte le macchine **Comacchio**, la **MC 20** può essere personalizzata in funzione delle specifiche esigenze



Variety of movements

The **MC 20** is a hydraulic drilling rig designed for civil engineering works such as micropiles, anchors and consolidations in general. Due to its patented mast articulation, a distinctive feature of the **MC 20** is the variety of movements and inclinations that it can perform. Combine this with the rig's high performance and reliability, it has the ability to tackle even the toughest working conditions. Equipped with advanced modular hydraulic circuits, the **MC 20** can accommodate a wide range of rotary heads, hydraulic hammers and double head systems (rotary-rotary and rotary-drifter). The **MC 20** can be equipped with hydraulic proportional servo-assisted controls or with the innovative **Comacchio** radio control system, which will manage all machine functions. Like all **Comacchio** rigs, the **MC 20** can be customized according to specific needs.



Large choix de positionnements

La **MC 20** est une foreuse hydraulique conçue pour les travaux de génie civil tels que micropieux, ancrages et confortement en général. Un des atouts de la **MC 20** est le large choix de positionnement et une cinématique à angles multiples grâce à l'articulation brevetée du mât, combinés avec la haute performance et la fiabilité, qui le permettent d'aborder même les conditions de travail les plus difficiles. Equipée de circuits hydrauliques modulaires de conception avancée, la **MC 20** peut s'adapter à une large gamme de têtes de rotation, marteaux hydrauliques, systèmes double-têtes (rotary-rotary et rotary-drifter) et est capable de réaliser tous types de forage en rotation ou roto-percussion. La **MC 20** peut être équipée de commandes hydrauliques de type proportionnel servo-assisté ou du système innovant de radiocommande **Comacchio** pour toutes les fonctions de la machine. Comme toutes les foreuses **Comacchio**, la **MC 20** peut être personnalisée selon les besoins du client.



Vielfältige Schwenk- und Einrichtungs-möglichkeiten

Die **MC 20** ist ein Hydraulikbohrgerät entwickelt für Spezialtiefbauarbeiten wie z.B. Mikropfähle, Anker und Bodenverbesserung im Allgemeinen. Ein besonderer Vorteil der **MC 20** sind die vielfältigen Schwenk- und Einrichtungs-möglichkeiten des Mastes durch die patentierte Kinematik, kombiniert mit hoher Leistung und Zuverlässigkeit, wodurch sie sich auch den härtesten Arbeitsbedingungen eignet. Dank ihrer fortschrittlichen modularen Hydraulikanlagen kann die **MC 20** mit einer breiten Palette von Drehantrieben, Hydraulikhämmern und Doppelkopfbohranlagen (drehend-drehend und drehend-schlagend) ausgerüstet werden und ist somit für sämtliche Bohrtechniken einsetzbar. Die Maschine kann mit hydraulisch-proportionaler Servosteuerung oder mit der innovativen **Comacchio** Funksteuerung für alle Gerätefunktionen ausgerüstet werden. Wie alle **Comacchio** Maschinen, kann die **MC 20** den Bedürfnissen des Kunden angepasst werden.



MC 20



Dati Tecnici - Technical Data - Caractéristiques Techniques - Technische Daten

Carro cingolato Undercarriage	Chariot chenille Fahrwerk		
Passo cingolo Wheel base	Enpattement Radstand	2.600 mm / 8,5 ft	
Larghezza max. Max width	Largeur max. Gesamtbreite	2.300 mm / 7,5 ft	
Larghezza suole Pad width	Largeur patins Kettenplattenbreite	450 mm / 17,7 in	
Pendenza max. Max. climbing ability	Pente max. Steigfähigkeit max.	36 %	
Velocità max. Max. speed	Vitesse max. Fahrgeschwindigkeit	2 km/h / 1,4 mph	
Centrale idraulica Power pack	Groupe hydraulique Hydraulikaggregat	<i>High Tech Line</i>	
Motore diesel Diesel engine	Moteur diesel Dieselmotor	DEUTZ TCD 2013 L06 STEP 3A / TIER 3	CATERPILLAR C7.1 STEP 4 / TIER 4 FINAL
Potenza motore Engine power		188 kW (252 HP) / 2200 rpm	205 kW (275 HP) / 2200 rpm
Serbatoio olio Oil tank	Réservoir huile Öltank	600 l / 158 gal	
Serbatoio gasolio Fuel tank	Réservoir diesel Dieseltank	200 l / 52 gal	
Mast Mast	Mât Lafette		
Corsa utile Feed stroke	Course utile Vorschub	4.200 - 4.800 mm / 13,7 - 15,7 ft	
Lunghezza totale Total length	Longueur totale Gesamtlänge	8.000 mm / 26,2 ft	
Forza di spinta Feed force	Poussée Vorschubkraft	9.500 daN / 21,357 lbs	
Forza di tiro Retract force	Traction Rückzugskraft	9.500 daN / 21,357 lbs	
Morse Clamps	Mors Klemm- und Brechvorrichtung		
Diametro min. / max di presa Clamping range	Tige diamètre min. / max Durchmesser min. / max	45 - 360 mm 1,8 - 14,1 in	45 - 420 mm 1,8 - 16,5 in
Forza di chiusura Clamping force	Force de serrage Klemmkraft	280 kN / 62,946 lbs	
Coppia svitaggio Breaking torque	Couple de deserrage Brechmoment	3.500 daNm / 25,814 lb*ft	
Ingombri Dimensions	Dimensions Aussenabmessungen		
Lunghezza Length	Longueur Länge	9.140 mm / 29,9 ft	
Larghezza Width	Largeur Breite	2.430 mm / 7,9 ft	
Altezza Height	Hauteur Höhe	3.390 mm / 11,1 ft	
Peso Weight	Poids Gewicht	19.500 - 22.000 kg / 43,000 - 48,500 lbs	

Dati Tecnici - Technical Data - Caractéristiques Techniques - Technische Daten

ROTARY

Tipo Type Type Typ	Marce Gears Vitesses Gänge	Coppia max. Max torque Couple max. Drehmoment max.	Giri max. Max speed Vitesse max. Drehzahl max.	Passaggio testa Head passage Passege de la tête Drehkopfdurchgang
R 2400	3	2.400 daNm / 17,701 lb*ft	153 rpm	116 mm / 4,5 in
R 3000 S	6	2.800 daNm / 20,651 lb*ft	210 rpm	128 mm / 5,0 in
R 3200	2/4	3.200 daNm / 23,602 lb*ft	72 rpm	116 mm / 4,5 in

DRIFTER

Tipo Type Type Typ	Marce Gears Vitesses Gänge	Coppia max. Max torque Couple max. Drehmoment max.	Giri max. Max speed Vitesse max. Drehzahl max.	Energia battuta Impact energy Energie par coup Einzelschlangenergie	Frequenza Frequency Fréquence Schlagfrequenz
HD 5012	2/4	1.410 daNm / 10,399 lb*ft	224 rpm	650 Nm / 479,4 lb*ft	2.300 min ⁻¹
HD 5017	3	1.680 daNm / 12,391 lb*ft	186 rpm	650 Nm / 479,4 lb*ft	2.300 min ⁻¹
HD 8021	2/4	2.400 daNm / 17,701 lb*ft	132 rpm	900 Nm / 663,8 lb*ft	2.200 min ⁻¹

ROTARY - ROTARY

Doppia testa Double head Double tête Doppelkopf	Tipo Type Type Typ	Marce Gears Vitesses Gänge	Coppia max. Max torque Couple max. Drehmoment max.	Giri max. Max speed Vitesse max. Drehzahl max.	Passaggio testa Head passage Passege de la tête Drehkopfdurchgang
Testa superiore Upper head Tête supérieure Oberer Kopf	R 900C	2/3/4	1.100 daNm / 8,113 lb*ft	190 rpm	68 mm / 2,6 in
Testa inferiore Lower head Tête inférieure Unterer Kopf	R 2400	3	2.400 daNm / 17,701 lb*ft	153 rpm	116 mm / 4,5 in
	R 3200	2/4	3.200 daNm / 23,602 lb*ft	72 rpm	116 mm / 4,5 in
	RH 3200	3	3.600 daNm / 25,552 lb*ft	122 rpm	135 mm / 5,3 in

ROTARY - DRIFTER

Doppia testa Double head Double tête Doppelkopf	Tipo Type Type Typ	Marce Gears Vitesses Gänge	Coppia max. Max torque Couple max. Drehmoment max.	Giri max. Max speed Vitesse max. Drehzahl max.	Energia battuta Impact energy Energie par coup Einzelschlangenergie	Frequenza Frequency Fréquence Schlagfrequenz
Testa superiore Upper head Tête supérieure Oberer Kopf	HD 4010	2	1.100 daNm / 8,113 lb*ft	138 rpm	500 Nm / 368,7 lb*ft	2.400 min ⁻¹
	HD 5012	2/4	1.410 daNm / 10,399 lb*ft	224 rpm	650 Nm / 479,4 lb*ft	2.300 min ⁻¹
Testa inferiore Lower head Tête inférieure Unterer Kopf	R 2400	3	2.400 daNm / 17,701 lb*ft	153 rpm	-	-
	R 3200	2/4	3.200 daNm / 23,602 lb*ft	72 rpm	-	-

Opzioni ed Accessori - Options and Accessories - Options et Accessoires - Optionen und Zubehör

Martello idraulico / Hydraulic drifter
Tête à rotopercussion / Hydraulikhammer

Doppia testa / Double head
Double tête / Doppelkopfanlage

Carrello estrattore / Casing extractor
Extracteur hydraulique / Schutzrohr-Ausziehvorrichtung

Morsa doppia / Double clamp
Double mors / Doppelklemme

Argano idraulico / Hydraulic winch
Treuil hydraulique / Hydraulische Seilwinde

Pompa schiumogeno / Foam pump
Pompe à mousse / Schaumpumpe

Pompa triplex / Triplex pump
Pompe triplex / Triplexpumpe

Lubrificatore di linea / D.T.H. lubricator
Graisseur de ligne / Linienöler

Gru idraulica / Hydraulic crane
Grue hydraulique / Hydraulikkran

Preventer / Preventer
Éjecteur / Preventer

Radiocomando / Remote radio control
Radiocommande / Funkfernsteuerung

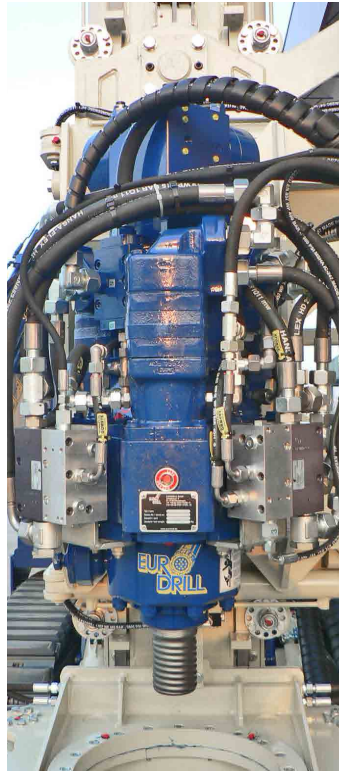

Dimensioni di ingombro - Overall dimensions - Dimensions - Aussenabmessungen

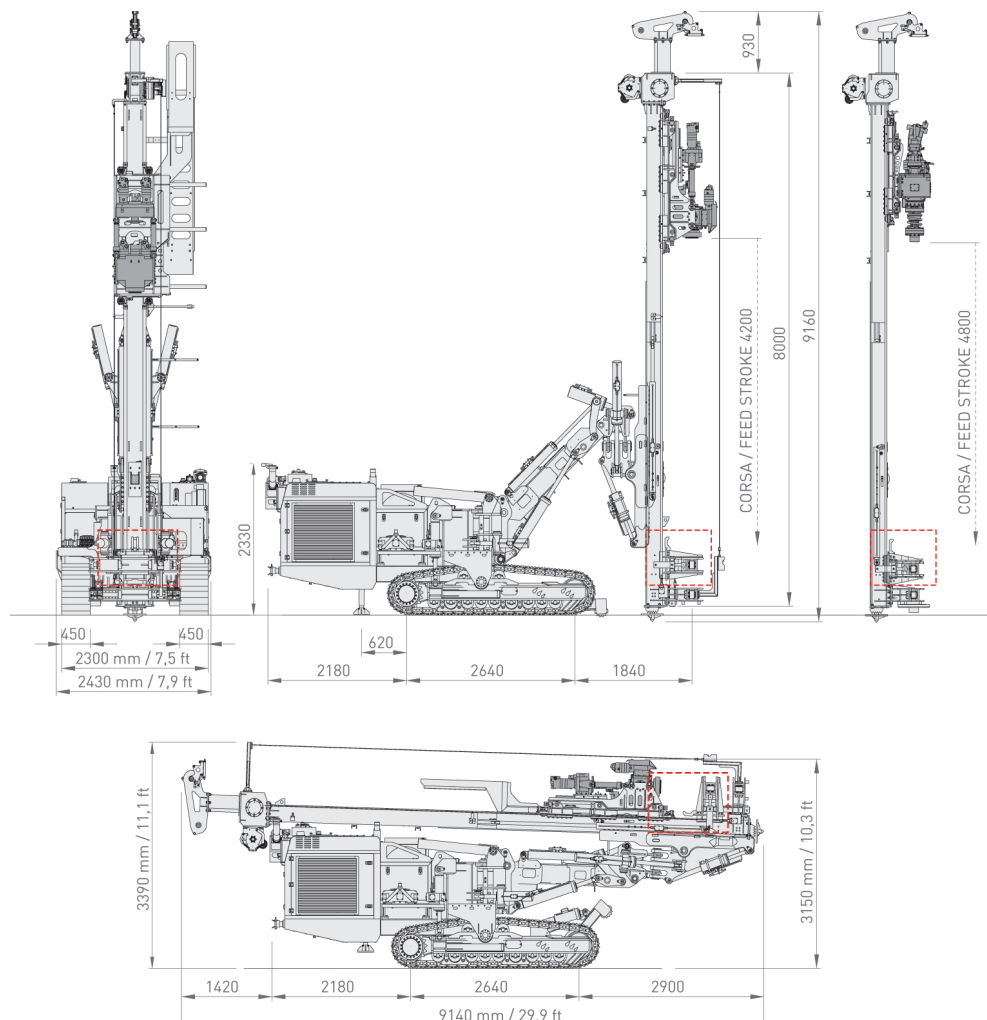

Movimenti Mast - Mast Movements - Cinématique du Bras - Volle Gelenkmöglichkeit

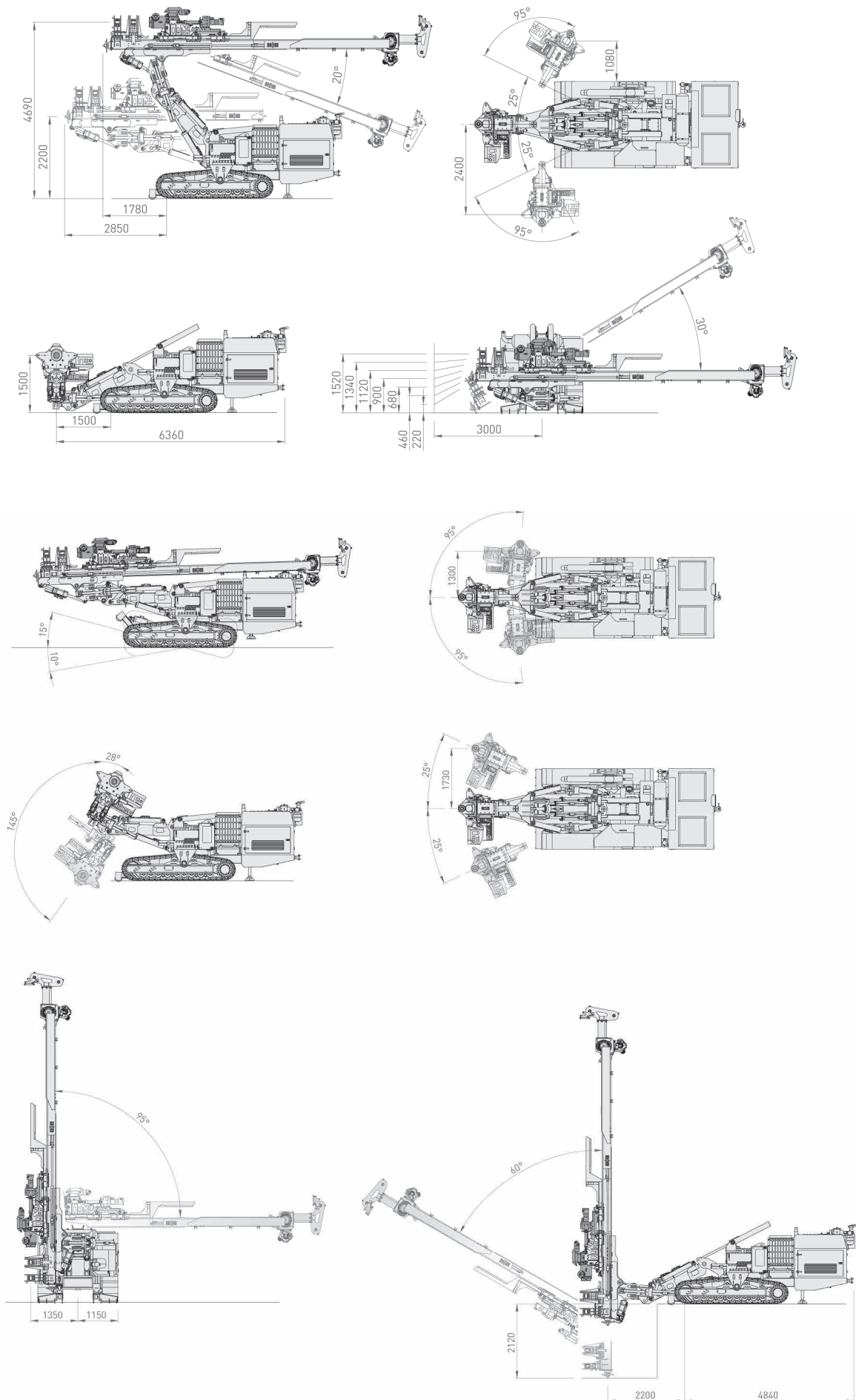



Comacchio s.r.l.

Via Callalta, 24/B - 31039 Riese Pio X (TV) (Italy)
Tel +39 0423 7585 - Fax + 39 0423 755592

www.comacchio.com

www.studiorubin.com - Printed 05-2017

I dati tecnici sono indicativi e soggetti a modifiche senza preavviso. / Specifications shown are only indicative and subject to alterations without prior notice
Les données techniques sont indicatives et sujettes à des modifications sans préavis / Die angegebenen Daten sind Richtwerte und können sich ohne Vorankündigung ändern.